



Klein®



TRIMATIC 22,4 FORATURA PER "LAMELLO® CABINEO®" TRIMATIC 22,4 FOR "LAMELLO® CABINEO®"

La **SISTEMI**, attenta come sempre alle esigenze ed alle problematiche nella lavorazione del legno, ha messo a punto un nuovo prodotto il Trimatic 22,4: l'unica attrezzatura presente sul mercato che consente con un normale trapano a colonna o un trapano elettrico portatile di eseguire la foratura dei tre fori ciechi per l'inserimento della giunzione **Lamello® Cabineo®** in modo facile e veloce. Si rivolge a tutti gli artigiani, hobbisti e fai da te che non sono in possesso di una macchina CNC.

***SISTEMI** has always paid special attention to the demands of woodworkers and their issues in the woodworking. For this reason, we have developed Trimatic 22,4: the new and only drilling jig on the market that can drill the required three blind holes for mounting **Lamello® Cabineo®** furniture connection, in a single pass simply using a power portable drill or stationary pillar drill. It is especially thought for hobbyists, artisans and craftsmen who do not own CNC router machines.*



YouTube



NEW trimatic®

Articolo/Item
TRIMATIC 22,4



Cabineo® è un prodotto/Cabineo® is a product of 

www.sistemiklein.com

COME È FATTO/HOW IT'S MADE

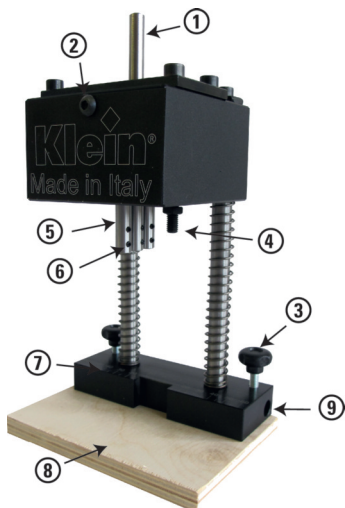

- 1) Attacco per mandrino trapano
- 2) Foro filettato per ingrassaggio
- 3) Pomello di bloccaggio asta di battuta laterale
- 4) Vite di regolazione profondità dei fori
- 5) Boccole porta utensili
- 6) Viti di bloccaggio utensili
- 7) Base con scala millimetrata
- 8) Tavoletta sostegno attrezzatura
- 9) Foro di scorrimento asta battuta laterale

- 1) Arbor for pillar drill spindle
- 2) Threaded hole for greasing
- 3) Locking knob for stop reference rod
- 4) Threaded screw for depth adjustment
- 5) Tool holder bush
- 6) Tool locking screw
- 7) Basement with millimetric scale
- 8) Equipment support table
- 9) Stop rod sliding hole

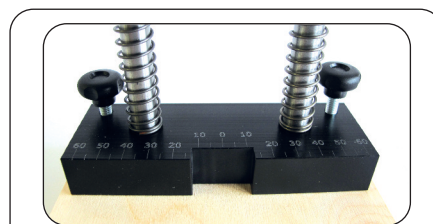

La speciale scala millimetrata alla base del trimatic vi faciliterà nella foratura del foro cieco $\varnothing 5$ mm nel pannello corrispondente per stringere la vite della giunzione Cabineo®.

The special millimetric scale on the basement will help you to make the $\varnothing 5$ mm hole in the corresponding workpiece to tighten the screw of Cabineo® with accuracy

UTENSILI (non inclusi)/TOOLING (not included)

A) Attrezzare il Trimatic 22,4 con le punte HW L174.150.R e L174.150.L come da disegno (1) per eseguire la foratura per l'inserimento del giunto "Lamello® Cabineo®".
Equip Trimatic 22,4 with HW drill bits (item L174.150.R e L174.150.L) as per drawing (1) to make the three holes for inserting "Lamello® Cabineo®" connections.

S $\varnothing 6$	Descrizione/Description	Rotazione/Rotation
L174.150.R	$\varnothing 15 \times 35$	Dx/Rh
L174.150.L	$\varnothing 15 \times 35$	Sx/Lh



L174.150.R



L174.150.L (x2)

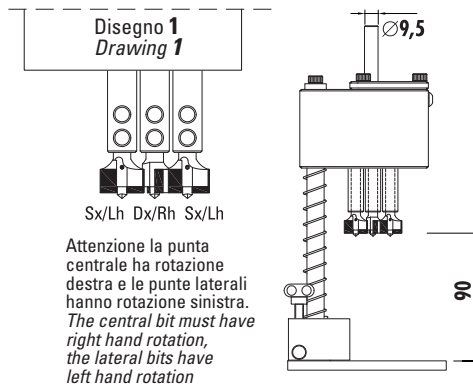
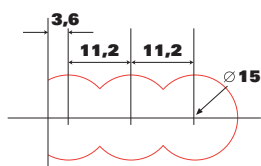

B) Attrezzare il Trimatic 22,4 (come da disegno 2) con la punta L175.050.L (per "Cabineo 8") o L175.051.L (per "Cabineo 12") per eseguire il foro $\varnothing 5$ mm per fissare il giunto "Lamello® Cabineo®". La distanza del foro dal bordo del pannello si ottiene mettendo in battuta uno spessore **C** (vedi disegno 2) la cui dimensione si calcola in funzione dello spessore del pannello **D** come da tabella (3).
Equip Trimatic 22,4 (as per drawing 2) with one of the drill bits L175.050.L (for "Cabineo 8") or L175.051.L (for "Cabineo 12") to make $\varnothing 5$ mm holes to fix Lamello® Cabineo® connections. The distance between this hole and the edge of the panel is achieved with an adjustment stop **C** (see drawing 2) whose thickness is determined by the thickness of the panel **D**, as per table (3) below.

(3) Tabella spessore battuta **C** in funzione dello spessore del pannello **D**
(3) Table to determine thickness of stop **C** in accordance with thickness of panel **D**

S $\varnothing 6$	Descrizione/Description	Rotazione/Rotation
L175.050.L	$\varnothing 5 \times 8 \times 35$ - "Cabineo 8"	Sx/Lh
L175.051.L	$\varnothing 5 \times 12 \times 39$ - "Cabineo 12"	Sx/Lh

D= Spessore pannello D= Panel thickness	C= Spessore battuta C= Adjustment stop thickness
12 mm	19 mm
14 mm	17 mm
16 mm	15 mm
18 mm	13 mm (incluso/included)
20 mm	11 mm
22 mm	9 mm
24 mm	7 mm
25 mm	6 mm



L175.050.L/L175.051.L

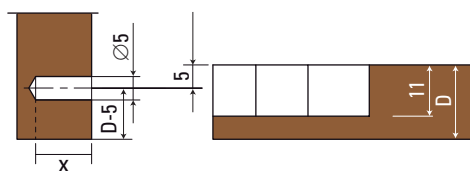
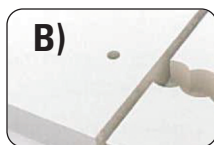

Punta $\varnothing 5$ mm Drill bit $\varnothing 5$ mm
Cabineo 8: X= 8 mm
Cabineo 12: X= 12 mm

